

# MCU with JFOPS4 for Electric Power Steering

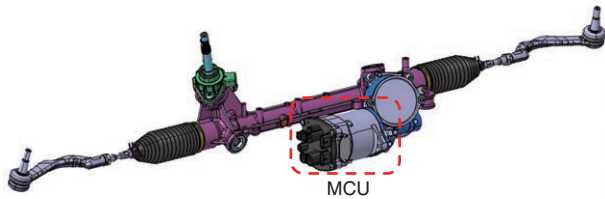

We have begun mass production of an MCU\*1 for electric power steering that provides safety and comfortable maneuverability by using a redundant design that allows assistance to continue even in the event of a failure.

\*1 MCU: Motor Control Unit

## Development Objectives

- To ensure a high degree of safety with the potential to support autonomous driving by adopting the JFOPS4\*2
  - To improve steering feel by adopting a newly developed steering control
- \*2 JFOPS4: JTEKT Fail-Operational System  
JTEKT's proprietary safety concept

## Features

### ①JFOPS4

Use of the JFOPS4 enables assistance to be continued using the remaining functional circuits, even in the unlikely event of a steering MCU failure.

Its hardware consists of two circuits for redundancy, including the motor drive circuit, torque sensor, motor position sensor, micro controller, power supply circuit, and CAN.

### ②Adoption of new-generation steering control, JWill\*3

Through meticulous tuning, it is now possible to provide a wide range of customers with the steering feel they desire.

\*3 JWill: New-generation EPS control that improves steering feel by incorporating torque feedback

JFOPS	Concept	SLOA * 4 ASIL * 5	Main targets	Assistance performance after a failure
4	<ul style="list-style-type: none"> <li>• Assistance continues without decreased functionality, even after a hardware failure</li> </ul>	ASIL-D	Autonomous driving	50% to 100%
3	<ul style="list-style-type: none"> <li>• Assistance continues after most single point hardware failures</li> <li>• High-level limp home 100%</li> <li>• Assistance stops only after a limited number of single point hardware failures</li> </ul>	ASIL-B or ASIL-C	Advanced Driving-Assistance System Large passenger vehicle	50% or more
2	<ul style="list-style-type: none"> <li>• Assistance continues with decreased functionality after most single point hardware failures</li> <li>• Limp home 100%</li> <li>• Assistance stops after some single point hardware failures</li> </ul>	ASIL-B	Medium passenger vehicle ~ Large passenger vehicle	20% or more
1	<ul style="list-style-type: none"> <li>• Assistance stops after most single point hardware failures</li> <li>• Assistance continues with decreased functionality after some single point hardware failures</li> </ul>	ASIL-B	Small passenger vehicle ~ Medium passenger vehicle	20% or less
0	<ul style="list-style-type: none"> <li>• Assistance stops after a hardware failure</li> </ul>	QM (Quality Management)	Small passenger vehicle	SLOA

\* 4 SLOA: Sudden Loss of Assist

SLOA indicates a failure mode in which electric power steering assistance stops suddenly.

\* 5 ASIL: Automotive Safety Integrity Level

ASIL is a risk classification system defined by ISO 26262 standard.

JTEKT CORPORATION

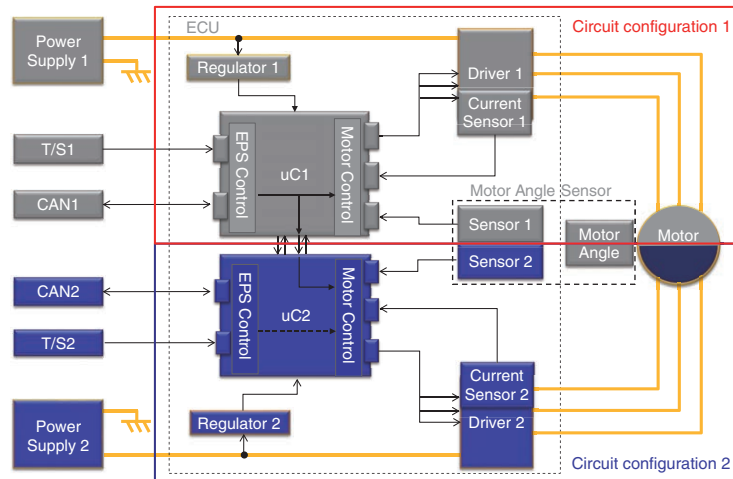

\* JWill is a registered trademark of JTEKT Corporation.

(Fundamental Technology Development Dept. 2, Automotive Business Unit)